

MTL 910x-22

Redundant, 4-segment FISCO power supply system - IIB Gas Groups

- **Redundant power supply configuration for high system availability**
- **4 segments**
- **Enhancement of field-proven 912x-IS FISCO power supply**
- **For IIB Gas Groups**
- **Variants for direct integration into proprietary fieldbus control systems**
- **Rugged construction for easy cabinet mounting and resistance to shock and vibration**



System Overview

The 910x power supply systems provide an intrinsically safe field network for FOUNDATION™ fieldbus systems in hazardous areas. Variants are available for integration into proprietary fieldbus control systems. The output of the power supply modules complies with the Fieldbus Intrinsically Safe Concept (FISCO) model, in accordance with IEC standard 60079-27. The key advantages of FISCO over earlier 'Entity' model installations to FF-816 are higher available field current and reduced safety documentation, while retaining the ability to conduct maintenance while energised and without 'gas clearance'.

The 910x systems build on MTL 912x-IS range of power supplies, which have become established as the industry standard solution for FISCO networks. The 910x systems now achieve higher levels of overall system availability by providing redundancy of the power modules.

When used with intrinsically safe versions of MTL Megablock field wiring hubs, the power supply systems allow complete FISCO networks to be assembled for even the most demanding process applications.

Architecture

Each IS fieldbus segment is powered by a redundant pair of pluggable FISCO power supply modules. The modules operate in active/hot standby mode, ensuring that the fieldbus segments are continually powered. In the event of a failure of an active power supply module, the field circuit is automatically transferred to the standby module. The change-over is managed by Supply Arbitration Modules (SAMs), which monitor the health of the FISCO power supplies while maintaining intrinsic safety requirements during the transition to the standby module. The SAMs are also duplicated and replaceable, meaning that there are no non-redundant system components.

Switch-over is achieved rapidly and in accordance with Foundation fieldbus™ specifications, and without risk of losing fieldbus devices from the bus. A combination of LED diagnostics and alarm signalling provides failure notification of FISCO power supplies and SAMs, allowing failed hardware to be identified and full redundancy to be restored by module replacement.

MTL 910x-22

February 2017

Carrier

The module carrier provides fieldbus power for four fieldbus segments. It supports pluggable power supply and arbitration modules for each segment and all connection facilities. Each carrier has connections for redundant 24V input power, host fieldbus segments and intrinsically safe field trunks. A volt-free failure alarm is also provided for connection to a digital input module. There are no active electronic circuits on the carrier, resulting in long calculated Mean Time to Failure (MTTF) and overall high system availability.

The carrier dimensions are designed to provide high packing density in typical 800mm wide equipment cabinets. Survival in high-vibration marine environments is achieved by secure panel-mount fixings.

The FISCO power supply module is a pluggable -22 version of MTL 912x-IS power supplies, and supports the same level of features. LED indicators provide information on system health and assist with fault diagnosis.

REDUNDANCY BLOCK DIAGRAM (one segment shown)

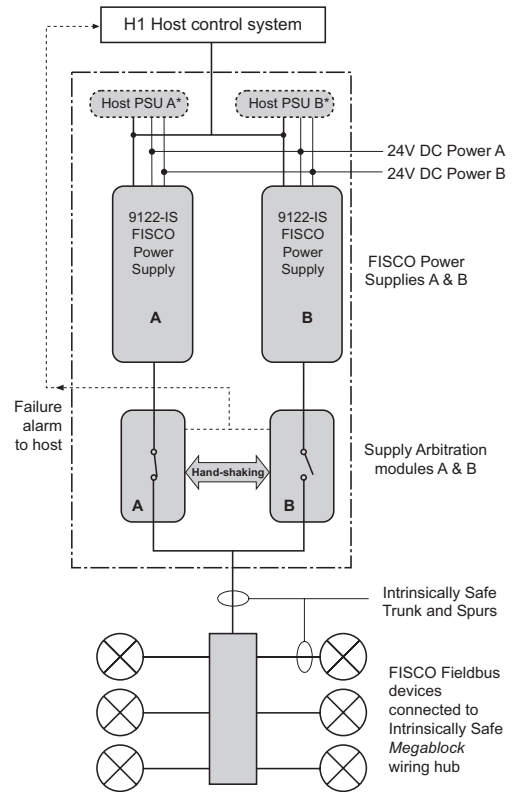

DIMENSIONS (mm) - (9107-22-PS model shown)

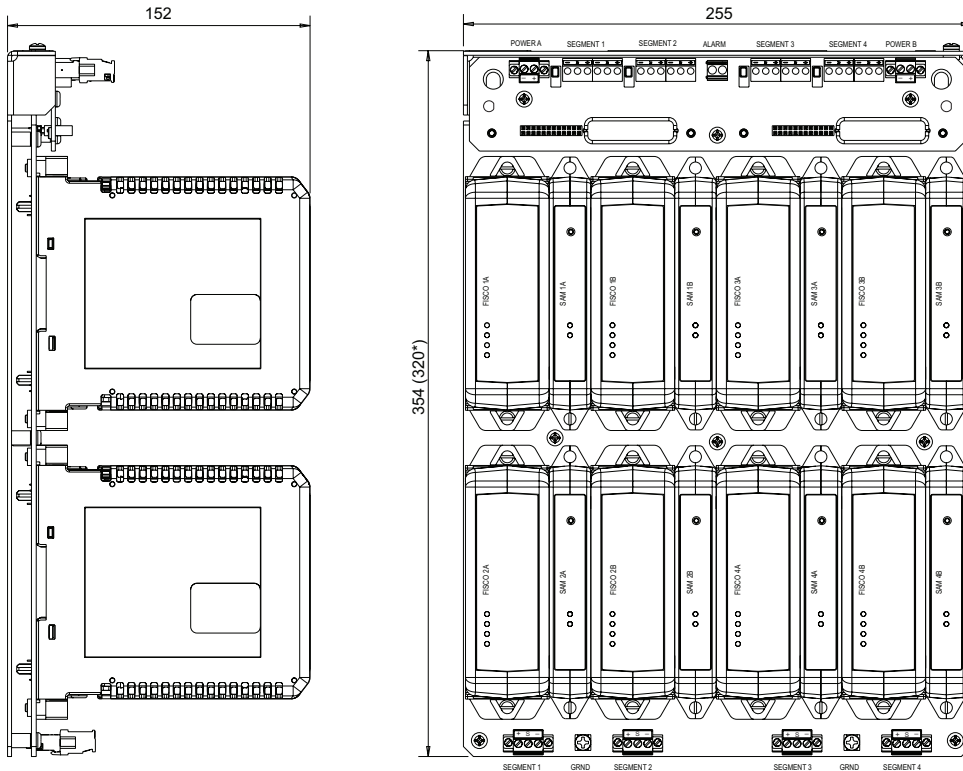

(* 320mm dimension applies to 9108-xx model)

MTL 910x-22

February 2017

SPECIFICATION

OUTPUTS

Number of segments

Four

Voltage @ 25°C

12.9 min.

Note: Temperature coefficient 12mV/°C maximum. If the power supply and fieldbus cable are operated at low temperatures, the reduced resistance of the cable more than compensates for the reduction in output voltage.

Design current

0 to 245mA

Current limit

> 270mA

Output ripple

Complies with clause 12.7.3 of EN61158-02:2004

Minimum load

No load

Isolation

Host fieldbus to intrinsically safe fieldbus: 250V ac rms
Host/intrinsically safe fieldbus to power supply: 250V ac rms
Um = 253V rms

INPUTS

Input voltage

19.2 - 30V dc

Current consumption per segment (full load)

570 mA (typical) 625 mA (max.) at 24V

Note: Some variants may draw additional current where optional host power modules are supported - consult MTL product line.

Power dissipation per segment

@200mA load 9.7W (typical) 10.2W (max.)

Power dissipation per segment (full load)

10.3W (typical) 11.5W (max.)

SAFETY

Location of fieldbus power supply carrier

Safe area or Zone 2 IIC T4 hazardous area depending on model.

Location of field wiring

Zone 1, IIB hazardous area

Field wiring protection

Intrinsically safe

Safety description, each segment

14.8V, 359mA, 5.31W, 0.50µF*, 550µH

* When used in accordance with IEC60079-27, there is no need to take into consideration Co and Lo.

Certification markings

Depends upon model chosen - see specific data sheet

Certificate numbers

ATEX: Depends upon model chosen - see specific data sheet

IECEX: Depends upon model chosen - see specific data sheet

Certification is compatible with

- Fieldbus Foundation™ FF816-FISCO.
- IEC 60079-27 FISCO Standard
- EC Directive 94/9/EC

FIELDBUS TERMINATION

One fixed, plus one fixed or switchable terminator per host segment on module carrier (depending upon model).

Fixed terminator per field segment inside each 9122-IS module.

CONNECTIONS

Hazardous area fieldbus

3-way pluggable rising cage-clamp screw terminals per segment
Conductor size: 0.14 to 2.5 mm²

Host fieldbus

Screw or sprung cage clamp terminals or proprietary host connector - determined by model type

24V power

2-way pluggable rising cage-clamp screw terminal each for Power A and Power B
Conductor size: 0.14 to 2.5 mm²

Alarm

2-way rising cage-clamp screw terminal
Conductor size: 0.14 to 2.5 mm²

ALARMS

Alarm contact rating

Max. 250V, 100mA (solid state)

Alarm contact status

Normally closed, open on failure of any FISCO power supply module or Supply Arbitration Module

MECHANICAL

Mounting

Surface mounting

Weight

5-6kg approx. depending upon model

Dimensions

Refer to diagram.

ENVIRONMENTAL

Ambient temperature

-20°C to +60°C (operating)

-40°C to +85°C (storage)

Ingress protection

IP20 to BS EN 60529 (Additional protection by means of enclosure)

LED INDICATORS

Carrier Power Inputs

	OFF	ON
Power (green)	Power fail	Power OK

FISCO Power Supply

	OFF	ON
Power (green)	Power fail or internal fault	Power OK
Fault (red)	Normal	Fault
Host Comm (yellow)	Comms failure	Comms OK
IS Comm (yellow)	Comms failure	Comms OK

Supply Arbitration Module (SAM) - 9129-IS

Active Mode	Active LED - ON	Standby LED - OFF
Standby Mode	Active LED - OFF	Standby LED - ON
Fault/Alarm Mode	Active LED or Standby LED - OFF or FLASHING †	

† During startup, either of the LEDs may flash for up to 10 seconds - this is normal operation.

Patents applied for.

MTL 910x-22

February 2017

ORDERING INFORMATION

Model Number	Description	For use with:
9101-22-PS*	Redundant FISCO power supply system, 4-segment pluggable screw terminals	Invensys Foxboro I/A
9107-22-PS*	Redundant FISCO power supply system, 4-segment, pluggable screw terminals	Universal, non-powered host control systems
9108-22-PS	Redundant FISCO power supply system, 4-segment, pluggable screw terminals	Yokogawa CENTUM CS3000
9108-22-PC	Redundant FISCO power supply system, 4-segment, pluggable spring clamp terminals	Yokogawa CENTUM CS3000
9109-22-PS*	Redundant FISCO power supply system, 4-segment, pluggable screw terminals	Universal, powered host control systems †, including: Emerson DeltaV and Honeywell Series 'C' I/O

* Consult MTL product line for availability

† 9109-22-PS provides 30mA to energise H1 card in host control system. 9107-22-PS does not.



Eaton Electric Limited,
Great Marlings, Butterfield, Luton
Beds, LU2 8DL, UK.
Tel: + 44 (0)1582 723633 Fax: + 44 (0)1582 422283
E-mail: mtlenquiry@eaton.com
www.mtl-inst.com

© 2017 Eaton
All Rights Reserved
Publication No. EPS 910x-2x Rev 4 020217
February 2017

EUROPE (EMEA):
+44 (0)1582 723633
mtlenquiry@eaton.com

THE AMERICAS:
+1 800 835 7075
mtl-us-info@eaton.com

ASIA-PACIFIC:
+65 6 645 9888
sales.mtlsing@eaton.com

The given data is only intended as a product description and should not be regarded as a legal warranty of properties or guarantee. In the interest of further technical developments, we reserve the right to make design changes.

MTL 9101-22

4-segment, redundant, FISCO power supply

- **Redundant power supply configuration for high system availability**
- **245mA output per segment for IIB Gas Groups**
- **For Invensys Foxboro I/A[®] series control systems**
- **Enhancement of field-proven 912x-IS FISCO power supply**
- **Rugged construction for easy cabinet mounting and resistance to shock and vibration**



System Overview

The 9101 power supply system provides an intrinsically safe field network for FOUNDATION™ fieldbus systems in hazardous areas. It has host-side connections that allow direct integration into Invensys Foxboro I/A[®] series control systems by means of standard pre-assembled cables. For other DCS types, consult MTL product line for details of the complete 910x-22 power supply range.

The output of the power supply modules complies with the Fieldbus Intrinsically Safe Concept (FISCO) model, in accordance with IEC standard 60079-27. The key advantages of FISCO over earlier 'Entity' model installations to FF-816 are higher available field current and reduced safety documentation, while retaining the ability to conduct maintenance while energised and without 'gas clearance'.

The 9101 system builds on MTL 912x-IS range of power supplies, which have become established as the industry standard solution for FISCO networks. The 9101 system now achieves higher levels of overall system availability by providing redundancy of the power modules.

When used with intrinsically safe versions of MTL Megablock field wiring hubs, the power supply system allows complete FISCO networks to be assembled for even the most demanding process applications.

Architecture

Each IS fieldbus segment is powered by a redundant pair of pluggable FISCO power supply modules. The modules operate in active/hot standby mode, ensuring that the fieldbus segments are continually powered. In the event of a failure of an active power supply module, the field circuit is automatically transferred to the standby module. The change-over is managed by Supply Arbitration Modules (SAMs), which

monitor the health of the FISCO power supplies while maintaining intrinsic safety requirements during the transition to the standby module. The SAMs are also duplicated and replaceable, meaning that there are no non-redundant system components.

Switch-over is achieved rapidly and in accordance with FOUNDATION™ fieldbus specifications, and without risk of losing fieldbus devices from the bus. A combination of LED diagnostics and alarm signalling provides failure notification of FISCO power supplies and SAMs, allowing failed hardware to be identified and full redundancy to be restored by module replacement.

Carrier

The module carrier provides fieldbus power for four fieldbus segments. It supports pluggable power supply and arbitration modules for each segment and all connection facilities. Each carrier has connections for redundant 24V input power, host fieldbus segments and intrinsically safe field trunks. A volt-free failure alarm is also provided for connection to a digital input in the host Control System. There are no active electronic circuits on the carrier, resulting in long calculated Mean Time to Failure (MTTF) and overall high system availability.

The carrier dimensions are designed to provide high packing density in typical 800mm wide equipment cabinets. Survival in high-vibration marine environments is achieved by secure panel-mount fixings.

The FISCO power supply modules are pluggable versions of MTL 912x-IS range, and support the same level of features. LED indicators provide information on system health and assist with fault diagnosis.

SPECIFICATION

OUTPUTS

Number of segments

Four

Voltage

12.9V (min.) at 25°C (see note)

Design current

0 to 245mA

Current limit

>270mA

Output ripple

Complies with clause 12.7.3 of EN61158-02:2004

Minimum load

No load

Isolation

Host fieldbus to intrinsically safe fieldbus: 250V ac rms

Host/intrinsically safe fieldbus to power supply: 250V ac rms

Um = 253V rms

Note: Temperature coefficient 12mV/°C maximum. If the power supply and fieldbus cable are operated at low temperatures, the reduced resistance of the cable more than compensates for the reduction in output voltage.

INPUTS

Input voltage

19.2 - 30V dc

Current consumption per segment (full load):

570 mA (typical) 625 mA (max.) at 24V

Power dissipation per segment (200mA load):

9.7W (typical) 10.2W (max.)

Power dissipation per segment (full load):

10.3W (typical) 11.5W (max.)

SAFETY

Location of fieldbus power supply carrier

Safe area

Location of field wiring

Zone 1, IIB hazardous area

Field wiring protection

Intrinsically safe

Safety description, each segment

14.8V, 359mA, 5.31W, 0.50µF*, 550µH*

* When used in accordance with IEC60079-27, there is no need to take into consideration Co and Lo.

Certification

See 'Approvals' table

Certification is compatible with

- Fieldbus FOUNDATION FF816-FISCO
- IEC 60079-27 FISCO Standard
- EC Directive 94/9/EC

FIELDBUS TERMINATION

1 x fixed terminator and 1 x switchable terminator per host segment on module carrier

Fixed terminator per field segment inside each 9122-IS module

CONNECTIONS

Host fieldbus

25-pin subminiature D-type connector - compatible with Foxboro system cables from the P0916Dx series. (Select a cable of the appropriate length.)

Hazardous area fieldbus

3-way pluggable rising cage-clamp screw terminals per segment
Conductor size: 0.14 to 2.5 mm²

24V power - Power A and Power B

3-pin header - compatible with Foxboro power cables from the P0926Kx series. (Select a cable of the appropriate length.)

Alarm

2-way rising cage-clamp screw terminal

Conductor size: 0.14 to 2.5 mm²

ALARMS

Alarm contact rating

Max. 250V, 100mA (solid state)

Alarm contact status

Normally closed, open on failure of any FISCO power supply module or Supply Arbitration Module

MECHANICAL

Mounting

Surface mounting

Weight

6.0kg approx.

Dimensions (refer also to diagram)

255(w) x 354(h) x 154(d) mm

ENVIRONMENTAL

Ambient temperature

-20°C to +60°C (operating)

-40°C to +85°C (storage)

Ingress protection

IP20 to BS EN 60529 (Additional protection by means of enclosure)

LED INDICATORS

Carrier Power Inputs

	OFF	ON
Power (green)	Power fail	Power OK

FISCO Power Supply - 9122-IS-CM

	OFF	ON
Power (green)	Power fail or internal fault	Power OK
Fault (red)	Normal	Fault
Host Comm (yellow)	Comms failure	Comms OK
IS Comm (yellow)	Comms failure	Comms OK

Supply Arbitration Module (SAM) - 9129-IS

Active Mode	Active LED - ON	Standby LED - OFF
Standby Mode	Active LED - OFF	Standby LED - ON
Fault/Alarm Mode	Active LED or Standby LED - OFF or FLASHING*	

* Note: During startup, either of the LEDs may flash for up to 10 seconds - this is normal operation.

ORDERING INFORMATION

Description	Part Number
Redundant FISCO power supply system (4 segment, pluggable screw terminals, IIB Gas Group for Invensys Foxboro I/A) Comprises: 8 x 9122-IS-CM, 8 x 9129-IS, 1 x 9101-CA-PS	9101-22-PS
FISCO power supply (IIB Gas Group, pluggable carrier mount)	9122-IS-CM
Supply arbitration module	9129-IS
Alarm blanking module (To defeat carrier alarm if power supplies and supply arbitration modules are not fitted. Two required per segment)	9127-BLK
Module carrier (4 segment, pluggable screw terminals)	9101-CA-PS

**REDUNDANCY BLOCK DIAGRAM
(one segment shown)**

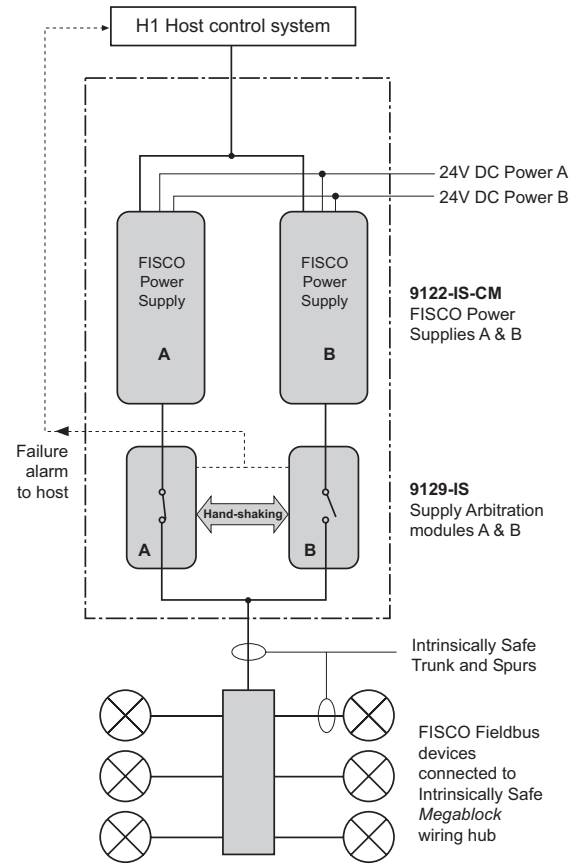

DIMENSIONS (mm)

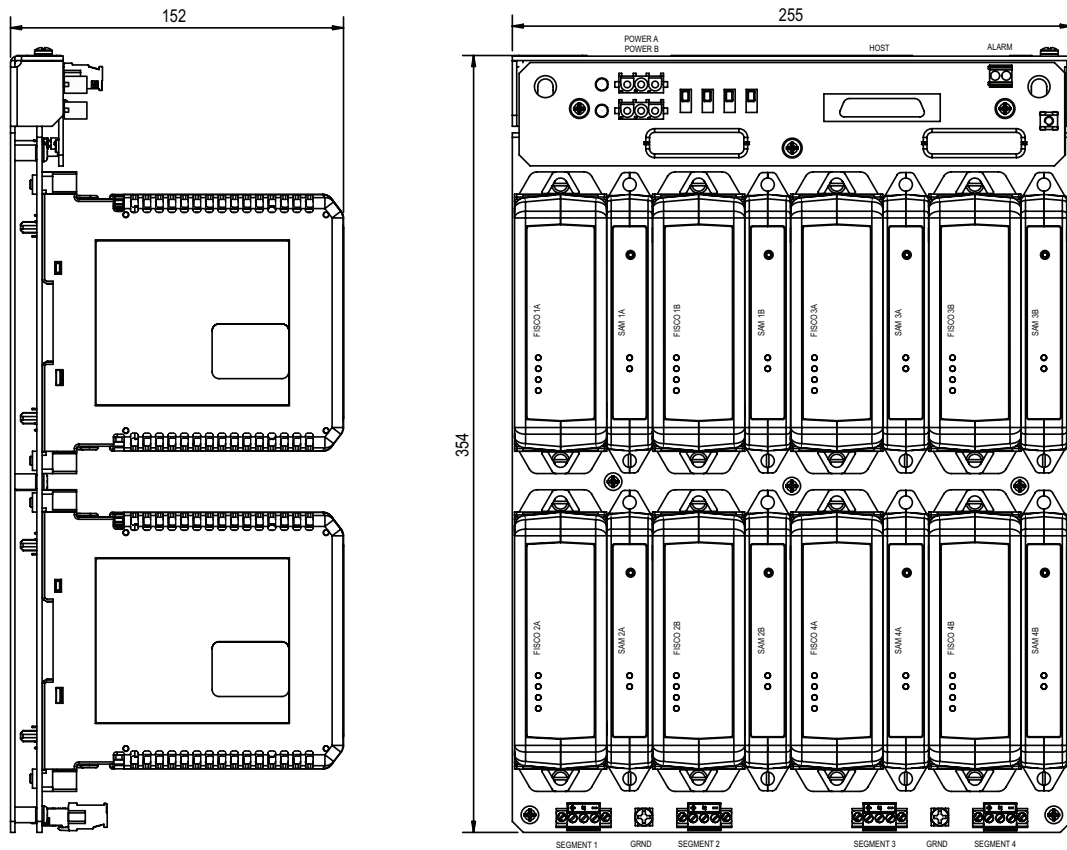

APPROVALS

Authority	Baseefa	IECEX
Standards	EN 60079-0 EN 60079-11 EN 60079-27 EN 61241-11	IEC 60079-0 IEC 60079-11 IEC 60079-27 IEC 61241-11
Certification markings	E II (2) GD [Ex ib Gb] IIB (-20°C ≤ T _a ≤ 60°C) [Ex ib Db] IIIC (-20°C ≤ T _a ≤ 60°C)	[Ex ib Gb] IIB (-20°C ≤ T _a ≤ 60°C) [Ex ib Db] IIIC (-20°C ≤ T _a ≤ 60°C)
Certification number	Baseefa09ATEX0127	IECEXBAS 09.0055



Eaton Electric Limited,
Great Marlings, Butterfield, Luton
Beds, LU2 8DL, UK.
Tel: + 44 (0)1582 723633 Fax: + 44 (0)1582 422283
E-mail: mtlenquiry@eaton.com
www.mtl-inst.com

© 2017 Eaton
All Rights Reserved
Publication No. EPS 9101-22 Rev 3 010217
February 2017

EUROPE (EMEA):
+44 (0)1582 723633
mtlenquiry@eaton.com

THE AMERICAS:
+1 800 835 7075
mtl-us-info@eaton.com

ASIA-PACIFIC:
+65 6 645 9888
sales.mtlsing@eaton.com

The given data is only intended as a product description and should not be regarded as a legal warranty of properties or guarantee. In the interest of further technical developments, we reserve the right to make design changes.

MTL 9107-22

4-segment, redundant, FISCO power supply, IIB gas groups

- **Redundant power supply configuration for high system availability**
- **4 segments**
- **Screw-terminal connections for host fieldbus segments**
- **245mA output per segment for IIB Gas Groups**
- **Enhancement of field-proven 912x-IS FISCO power supply**
- **Rugged construction for easy cabinet mounting and resistance to shock and vibration**



System Overview

The 9107 power supply system provides an intrinsically safe field network for FOUNDATION™ fieldbus systems in hazardous areas. Fixed screw terminals are provided for the host fieldbus connections*. The output of the power supply modules complies with the Fieldbus Intrinsically Safe Concept (FISCO) model, in accordance with IEC standard 60079-27 Edition 2.0 (2008). The key advantages of FISCO over earlier 'Entity' model installations to FF-816 are higher available field current and reduced safety documentation, while retaining the ability to conduct maintenance while energised and without 'gas clearance'.

The 9107 system builds on MTL 912x-IS range of power supplies, which have become established as the industry standard solution for FISCO networks. The 9107 system now achieves higher levels of overall system availability by providing redundancy of the power modules.

When used with intrinsically safe versions of MTL Megablock field wiring hubs, the power supply system allows complete FISCO networks to be assembled for even the most demanding process applications.

Architecture

Each IS fieldbus segment is powered by a redundant pair of pluggable FISCO power supply modules. The modules operate in active/hot standby mode, ensuring that the fieldbus segments are continually powered. In the event of a failure of an active power supply module, the field circuit is automatically transferred to the standby module. The change-over is managed by Supply Arbitration Modules (SAMs), which monitor the health of the FISCO power supplies while maintaining intrinsic safety requirements during the transition to the

standby module. The SAMs are also duplicated and replaceable, meaning that there are no non-redundant system components.

Switch-over is achieved rapidly and in accordance with FOUNDATION™ fieldbus specifications, and without risk of losing fieldbus devices from the bus. A combination of LED diagnostics and alarm signalling provides failure notification of FISCO power supplies and SAMs, allowing failed hardware to be identified and full redundancy to be restored by module replacement.

Carrier

The module carrier provides fieldbus power for four fieldbus segments. It supports pluggable power supply and arbitration modules for each segment and all connection facilities. Each carrier has connections for redundant 24V input power, host fieldbus segments and intrinsically safe field trunks. A volt-free failure alarm is also provided for connection to a digital input module. There are no active electronic circuits on the carrier, resulting in long calculated Mean Time to Failure (MTTF) and overall high system availability.

The carrier dimensions are designed to provide high packing density in typical 800mm wide equipment cabinets. Survival in high-vibration marine environments is achieved by secure panel-mount fixings.

The FISCO power supply modules are pluggable versions of MTL 9122-IS range, and support the same level of features. LED indicators provide information on system health and assist with fault diagnosis.

* Models are available for systems that use proprietary host cable/connector methods. Please enquire for details.

SPECIFICATION

OUTPUTS

Number of segments

Four

Voltage

12.9V (min.) at 25°C (see note)

Design current

0 to 245mA

Current limit

>270mA

Output ripple

Complies with clause 12.7.3 of EN61158-02:2004

Minimum load

No load

Isolation

Host fieldbus to intrinsically safe fieldbus: 250V ac rms

Host/intrinsically safe fieldbus to power supply: 250V ac rms

$U_m = 253V$ rms

Note: Temperature coefficient 12mV/°C maximum. If the power supply and fieldbus cable are operated at low temperatures, the reduced resistance of the cable more than compensates for the reduction in output voltage.

INPUTS

Input voltage

19.2 - 30V dc

Current consumption per segment (full load):

570 mA (typical) 625 mA (max.) at 24V

Power dissipation per segment (200mA load):

9.7W (typical) 10.2W (max.)

Power dissipation per segment (full load):

10.3W (typical) 11.5W (max.)

SAFETY

Location of fieldbus power supply carrier

Safe area

Location of field wiring

Zone 1, IIB hazardous area

Field wiring protection

Intrinsically safe

Safety description, each segment

14.8V, 359mA, 5.31W, 0.50 μ F*, 550 μ H*

* When used in accordance with IEC60079-27, there is no need to take into consideration Co and Lo.

Certification

See 'Approvals' table

Certification is compatible with

- Fieldbus Foundation FF816-FISCO.
- IEC 60079-27 FISCO Standard
- EC Directive 94/9/EC

FIELDBUS TERMINATION

1 x fixed terminator and 1x switchable terminator per host segment on module carrier

Fixed terminator per field segment inside each 9122-IS module

CONNECTIONS

Host fieldbus

2 x 3-way fixed rising cage-clamp screw terminals per segment
Conductor size: 0.14 to 2.5 mm²

Hazardous area fieldbus

3-way pluggable rising cage-clamp screw terminals per segment
Conductor size: 0.14 to 2.5 mm²

24V power

2-way pluggable rising cage-clamp screw terminal each for Power A and Power B

Conductor size: 0.14 to 2.5 mm²

Alarm

2-way fixed rising cage-clamp screw terminal

Conductor size: 0.14 to 2.5 mm²

ALARMS

Alarm contact rating

Max. 250V, 100mA (solid state)

Alarm contact status

Normally closed, open on failure of any FISCO power supply module or Supply Arbitration Module

MECHANICAL

Mounting

Surface mounting

Weight

6.3kg approx.

Dimensions (refer also to diagram)

255(w) x 354(h) x 154(d) mm

ENVIRONMENTAL

Ambient temperature

-20°C to +60°C (operating)

-40°C to +85°C (storage)

Ingress protection

IP20 to BS EN 60529 (Additional protection by means of enclosure)

LED INDICATORS

Carrier Power Inputs

	OFF	ON
Power (green)	Power fail	Power OK

FISCO Power Supply - 9122-IS-CM

	OFF	ON
Power (green)	Power fail or internal fault	Power OK
Fault (red)	Normal	Fault
Host Comm (yellow)	Comms failure	Comms OK
IS Comm (yellow)	Comms failure	Comms OK

Supply Arbitration Module (SAM) - 9129-IS

Active Mode	Active LED - ON	Standby LED - OFF
Standby Mode	Active LED - OFF	Standby LED - ON
Fault/Alarm Mode	Active LED or Standby LED - OFF or FLASHING*	

* Note: During startup, either of the LEDs may flash for up to 10 seconds - this is normal operation.

ORDERING INFORMATION

Description	Part Number
Redundant FISCO power supply system (4 segment, screw terminals, IIB Gas Group) Comprises: 8x 9122-IS-CM, 8 x 9129-IS, 1 x 9107-CA-PS	9107-22-PS
FISCO power supply (IIB Gas Group, pluggable carrier mount)	9122-IS-CM
Supply arbitration module	9129-IS
Alarm blanking module (To defeat carrier alarm- if power supplies and supply arbitration modules are not fitted. Two required per segment)	9127-BLK
Module carrier (4 segment, screw terminals)	9107-CA-PS

**REDUNDANCY BLOCK DIAGRAM
(one segment shown)**

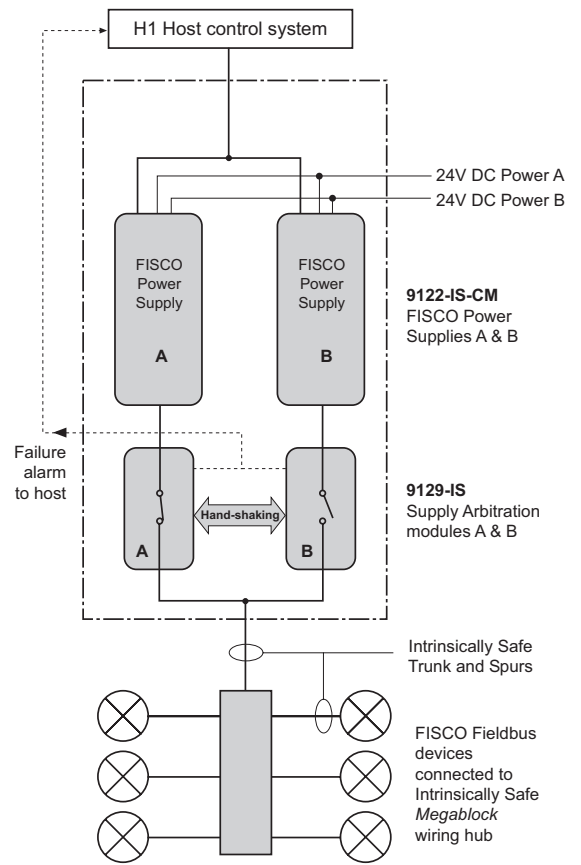

DIMENSIONS (mm)

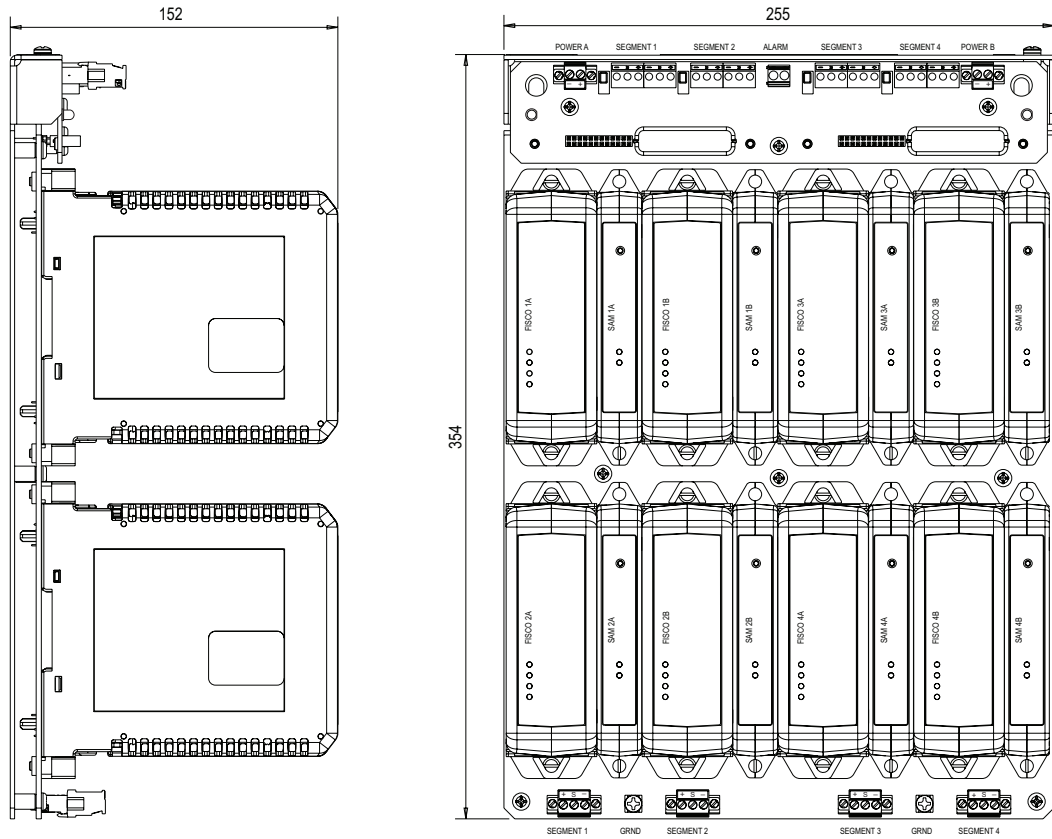

APPROVALS

Authority	ATEX	IECEx
Standards	EN 60079-0 EN 60079-11 EN 60079-27 EN 61241-11	IEC 60079-0 IEC 60079-11 IEC 60079-27 IEC 61241-11
Certification markings	E II (2) GD [Ex ib Gb] IIB (-20°C ≤ T _a ≤ 60°C) [Ex ib Db] IIIC (-20°C ≤ T _a ≤ 60°C)	[Ex ib Gb] IIB (-20°C ≤ T _a ≤ 60°C) [Ex ib Db] IIIC (-20°C ≤ T _a ≤ 60°C)
Certification number	Baseefa09ATEX0127	IECExBAS 09.0055



Eaton Electric Limited,
Great Marlings, Butterfield, Luton
Beds, LU2 8DL, UK.
Tel: + 44 (0)1582 723633 Fax: + 44 (0)1582 422283
E-mail: mtlenquiry@eaton.com
www.mtl-inst.com

© 2017 Eaton
All Rights Reserved
Publication No. EPS 9107-22 Rev 3 020217
February 2017

EUROPE (EMEA):
+44 (0)1582 723633
mtlenquiry@eaton.com

THE AMERICAS:
+1 800 835 7075
mtl-us-info@eaton.com

ASIA-PACIFIC:
+65 6 645 9888
sales.mtlsing@eaton.com

The given data is only intended as a product description and should not be regarded as a legal warranty of properties or guarantee. In the interest of further technical developments, we reserve the right to make design changes.

MTL 9108-22

Redundant FISCO power for Yokogawa CENTUM SC3000 - IIB Gas Groups

- **Redundant power supply configuration for high system availability**
- **4 segments**
- **Integrated connections to redundant ALF111 Foundation fieldbus™ communication modules**
- **245mA output per segment for IIB Gas Groups**
- **Enhancement of field-proven 912x-IS FISCO power supply**
- **Rugged construction for easy cabinet mounting and resistance to shock and vibration**



System Overview

The 9108 power supply system provides an intrinsically safe field network for FOUNDATION™ fieldbus systems in hazardous areas. The output of the power supply modules complies with the Fieldbus Intrinsically Safe Concept (FISCO) model, in accordance with IEC standard 60079-27. The key advantages of FISCO over earlier 'Entity' model installations to FF-816 are higher available field current and reduced safety documentation, while retaining the ability to conduct maintenance while energised and without 'gas clearance'.

The 9108 system builds on MTL 912x-IS range of power supplies, which have become established as the industry standard solution for FISCO networks. The 9108 system now achieves higher levels of overall system availability by providing redundancy of the power modules.

When used with intrinsically safe versions of MTL Megablock field wiring hubs, the power supply system allows complete FISCO networks to be assembled for even the most demanding process applications.

Architecture

Each fieldbus segment is powered by a redundant pair of pluggable FISCO power supply modules. The modules operate in active/hot standby mode, ensuring that the fieldbus segments are continually powered. In the event of a failure of an active power supply module, the field circuit is automatically transferred to the standby module. The change-over is managed by Supply Arbitration Modules (SAMs), which monitor the health of the FISCO power supplies while maintaining intrinsic safety requirements during the transition to the standby module. The SAMs are also duplicated and replaceable, meaning that there are no non-redundant system components.

Switch-over is achieved rapidly and in accordance with FOUNDATION™ fieldbus specifications, and without risk of losing fieldbus devices from the bus. A combination agnostics and alarm signalling provides failure notification of FISCO power supplies and SAMs, allowing failed hardware to be identified and full redundancy to be restored by module replacement.

Carrier

The module carrier provides fieldbus power for four fieldbus segments. It supports pluggable power supply and arbitration modules for each segment and all connection facilities. Each carrier has connections for redundant 24V input power, ALF111 fieldbus communication modules via AKB336 cables and intrinsically safe field trunks. A volt-free failure alarm is also provided for connection to a digital input module. There are no active electronic circuits on the carrier, resulting in long calculated Mean Time to Failure (MTTF) and overall high system availability.

The carrier dimensions are designed to provide high packing density in typical 800mm wide equipment cabinets. Survival in high-vibration marine environments is achieved by secure panel-mount fixings.

The FISCO power supply modules are pluggable versions of MTL 912x-IS range, and support the same level of features. LED indicators provide information on system health and assist with fault diagnosis.

The given data is only intended as a product description and should not be regarded as a legal warranty of properties or guarantee. In the interest of further technical developments, we reserve the right to make design changes.

**REDUNDANCY BLOCK DIAGRAM
(one segment shown)**

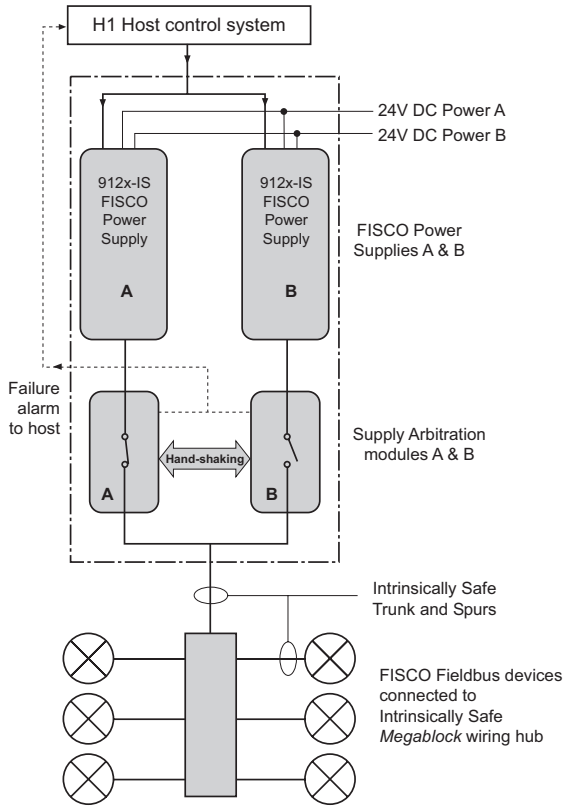

DIMENSIONS (mm)

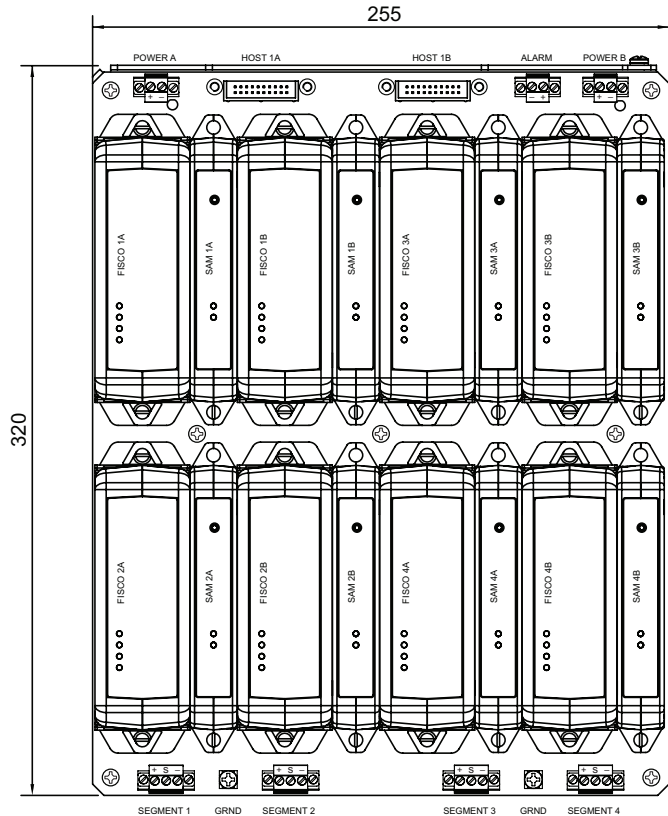
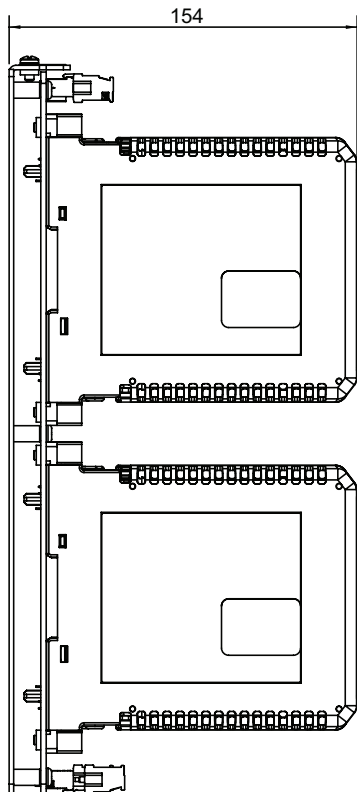

SPECIFICATION

OUTPUTS

Number of segments

Four

Voltage

12.9V (min.) at 25°C (see Note)

Design current

0 to 245mA

Current limit

>270mA

Output ripple

Complies with clause 12.7.3 of EN61158-02:2004

Minimum load

No load

Isolation

Host fieldbus to intrinsically safe fieldbus: 250V ac rms
 Host/intrinsically safe fieldbus to power supply: 250V ac rms
 Um = 253V rms

Note: Temperature coefficient 12mV/°C maximum. If the power supply and fieldbus cable are operated at low temperatures, the reduced resistance of the cable more than compensates for the reduction in output voltage.

INPUTS

Input voltage

19.2 - 30V dc

Current consumption per segment (full load):

570 mA (typical) 625 mA (max.) at 24V

Power dissipation per segment (200mA load):

9.7W (typical) 10.2W (max.)

Power dissipation per segment (full load):

10.3W (typical) 11.5W (max.)

SAFETY

Location of fieldbus power supply carrier

Safe area or Zone 2 IIB T4 hazardous area

Location of field wiring

Zone 1, IIB hazardous area

Field wiring protection

Intrinsically safe

Safety description, each segment

14.8V, 359mA, 5.31W, 0.50µF*, 550µH*

* When used in accordance with IEC60079-27, there is no need to take into consideration Co and Lo.

Certification codes

ATEX: E II (2) GD [Ex ib] IIB [Ex ibD]

IECEX: [Ex ib] IIB [Ex ibD]

Certificate numbers

ATEX: Baseefa09ATEX0127, MTL09ATEX9108X

IECEX: IECEX BAS 09.0055

Certification compatible with:

- Fieldbus Foundation FF816-FISCO
- IEC 60079-27 FISCO Standard
- EC Directive 94/9/EC

FIELDBUS TERMINATION

2 x fixed terminator per host segment on module carrier
 Fixed terminator per field segment inside each 9122-IS module

CONNECTIONS

Host fieldbus

Redundant shrouded multipin connectors to Yokogawa ALF111 host cards via AKB336 cables

Hazardous Area fieldbus

3-way pluggable rising cage-clamp screw terminal or spring clamp terminal per segment
 Conductor size: 0.14 to 2.5 mm²

24V power

2-way pluggable rising cage-clamp screw terminal each for Power A and Power B
 Conductor size: 0.14 to 2.5 mm²

Alarm

2-way pluggable rising cage-clamp screw terminal
 Conductor size: 0.14 to 2.5 mm²

ALARMS

Alarm contact rating

Max. 250V, 100mA (solid state)

Alarm contact status

Normally closed, open on failure of any FISCO power supply module or Supply Arbitration Module

MECHANICAL

Mounting

Surface mounting

Weight

5.5kg

Dimensions (refer also to diagram)

255(w) x 320(h) x 154(d) mm

ENVIRONMENTAL

Ambient temperature

-20°C to +60°C (operating)

-40°C to +85°C (storage)

Ingress protection

IP20 to BS EN 60529 (Additional protection by means of enclosure)

Marine approvals

Pending

LED INDICATORS

Carrier Power Inputs

	OFF	ON
Power (green)	Power fail	Power OK

FISCO Power Supply - 9122-IS-CM

	OFF	ON
Power (green)	Power fail or internal fault	Power OK
Fault (red)	Normal	Fault
Host Comm (yellow)	Comms failure	Comms OK
IS Comm (yellow)	Comms failure	Comms OK

Supply Arbitration Module (SAM) - 9129-IS

Active Mode	Active LED - ON	Standby LED - OFF
Standby Mode	Active LED - OFF	Standby LED - ON
Fault/Alarm Mode	Active LED or Standby LED - OFF or FLASHING*	

* Note: During startup, either of the LEDs may flash for up to 10 seconds - this is normal operation.

MTL 9108-22

February 2017

ORDERING INFORMATION

Description	Part Number
Redundant FISCO power supply system, (4 segment, pluggable screw terminals, IIB Gas Groups, for Yokogawa control systems) Comprises: 8x 9122-IS-CM, 8 x 9129-IS, 1 x 9108-CA-PS	9108-22-PS
Redundant FISCO power supply system (4 segment, pluggable spring clamp terminals, IIB Gas Groups, for Yokogawa control systems) Comprises: 8x 9122-IS-CM, 8 x 9129-IS, 1 x 9108-CA-PC	9108-22-PC
FISCO power supply, (IIB Gas Group, pluggable carrier mount)	9122-IS-CM
Supply arbitration module	9129-IS
Alarm blanking module (To defeat carrier alarm if power supplies and supply arbitration modules are not fitted. Two required per segment)	9127-BLK
Module carrier, (4 segment, pluggable screw terminals)	9108-CA-PS
Module carrier, (4 segment, pluggable spring clamp terminals)	9108-CA-PC



Eaton Electric Limited,
Great Marlings, Butterfield, Luton
Beds, LU2 8DL, UK.
Tel: + 44 (0)1582 723633 Fax: + 44 (0)1582 422283
E-mail: mtlenquiry@eaton.com
www.mtl-inst.com

© 2017 Eaton
All Rights Reserved
Publication No. EPS 9108-22 Rev 3 010217
February 2017

EUROPE (EMEA):
+44 (0)1582 723633
mtlenquiry@eaton.com

THE AMERICAS:
+1 800 835 7075
mtl-us-info@eaton.com

ASIA-PACIFIC:
+65 6 645 9888
sales.mtlsing@eaton.com

The given data is only intended as a product description and should not be regarded as a legal warranty of properties or guarantee. In the interest of further technical developments, we reserve the right to make design changes.

MTL 9109-22

4-segment, redundant, FISCO power supply

- Redundant power supply configuration for high system availability
- 245mA output per segment for IIB Gas Groups
- Redundant host power for Emerson DeltaV and Honeywell Experion-PKS Series C H1 cards
- 4 segments
- Enhancement of field-proven 912x-IS FISCO power supply
- Rugged construction for easy cabinet mounting and resistance to shock and vibration



System Overview

The 9109 power supply system provides an intrinsically safe field network for FOUNDATION™ fieldbus systems in hazardous areas. The output of the power supply modules complies with the Fieldbus Intrinsically Safe Concept (FISCO) model, in accordance with IEC standard 60079-27. The key advantages of FISCO over earlier 'Entity' model installations to FF-816 are higher available field current and reduced safety documentation, while retaining the ability to conduct maintenance while energised and without 'gas clearance'.

The 9109 system builds on the MTL 912x-IS range of power supplies, which have become established as the industry standard solution for FISCO networks. The 9109 system now achieves higher levels of overall system availability by providing redundancy of the power modules.

When used with intrinsically safe versions of MTL Megablock field wiring hubs, the power supply system allows complete FISCO networks to be assembled for even the most demanding process applications.

Architecture

Each IS fieldbus segment is powered by a redundant pair of pluggable FISCO power supply modules. The modules operate in active/hot standby mode, ensuring that the fieldbus segments are continually powered. In the event of a failure of an active power supply module, the field circuit is automatically transferred to the standby module. The change-over is managed by Supply Arbitration Modules (SAMs), which monitor the health of the FISCO power supplies while maintaining intrinsic safety requirements during the transition to the standby module. The SAMs are also duplicated and replaceable, meaning that there are no non-redundant system components.

Switch-over is achieved rapidly and in accordance with FOUNDATION™ fieldbus specifications, and without risk of losing fieldbus devices from the bus. A combination of LED diagnostics and alarm signalling provides failure notification of FISCO power supplies and SAMs, allowing failed hardware to be identified and full redundancy to be restored by module replacement.

Carrier

The module carrier provides fieldbus power for four fieldbus segments. It supports pluggable power supply and arbitration modules for each segment and all connection facilities. Each carrier has connections for redundant 24V input power, host fieldbus segments and intrinsically safe field trunks. A volt-free failure alarm is also provided for connection to a digital input module. There are no active electronic circuits on the carrier, resulting in long calculated Mean Time to Failure (MTTF) and overall high system availability.

The carrier dimensions are designed to provide high packing density in typical 800mm wide equipment cabinets. Survival in high-vibration marine environments is achieved by secure panel-mount fixings.

The FISCO power supply modules are pluggable versions of MTL 912x-IS range, and support the same level of features. LED indicators provide information on system health and assist with fault diagnosis.

Redundant host power

The 9109-22 power supply is intended for control systems equipped with H1 interface cards requiring current from the host fieldbus segment in order to operate. Such systems include Emerson DeltaV and Honeywell Experion-PKS with 4-link Fieldbus Interface Module.

The 9109 system is therefore equipped with redundant, pluggable 9126-PU power supply modules that provide up to 30mA for each of the four segments. These modules are also duplicated and replaceable.

The given data is only intended as a product description and should not be regarded as a legal warranty of properties or guarantee. In the interest of further technical developments, we reserve the right to make design changes.



Eaton Electric Limited,
Great Marlings, Butterfield, Luton
Beds, LU2 8DL, UK.
Tel: + 44 (0)1582 723633 Fax: + 44 (0)1582 422283
E-mail: mtlenquiry@eaton.com
www.mtl-inst.com

© 2017 Eaton
All Rights Reserved
Publication No. EPS 9109-22 Rev 3
February 2017

EUROPE (EMEA):
+44 (0)1582 723633
mtlenquiry@eaton.com

THE AMERICAS:
+1 800 835 7075
mtl-us-info@eaton.com

ASIA-PACIFIC:
+65 6 645 9888
sales.mtlsing@eaton.com

SPECIFICATION

OUTPUTS

Number of segments

Four

Voltage

12.9V (min.) at 25°C (see note)

Design current

0 to 245mA

Current limit

>270mA

Output ripple

Complies with clause 12.7.3 of EN61158-02:2004

Minimum load

No load

Isolation

Host fieldbus to intrinsically safe fieldbus: 250V ac rms
Host/intrinsically safe fieldbus to power supply: 250V ac rms
 $U_m = 253V$ rms

Note: Temperature coefficient 12mV/°C maximum. If the power supply and fieldbus cable are operated at low temperatures, the reduced resistance of the cable more than compensates for the reduction in output voltage.

INPUTS

Input voltage

19.2 - 30V dc

Current consumption per segment (full load):

570 mA (typical) 625 mA (max.) at 24V

Power dissipation per segment (200mA load):

9.7W (typical) 10.2W (max.)

Power dissipation per segment (full load):

10.3W (typical) 11.5W (max.)

Host power supply current consumption

The current drawn by the 9126-PU modules to provide power to the host H1 card depends on the number of host segments connected; the host demand current per segment; and the nominal power supply voltage. The table below provides a guide to the typical current drawn by a pair of 9126-PU modules.

For example, the current drawn by a pair of 9126-PU modules from a 24V supply, supporting 4 segments, each demanding 24mA, is ~198mA.

No. Of segs.	Host demand current			Supply voltage
	12mA	24mA	30mA	
1	Typical 9126-PU supply current (mA)			
	140	152	158	19.2V
	137	146	150	24V
2	138	144	148	30V
	152	175	187	19.2V
	147	163	172	24V
3	145	158	165	30V
	164	200	216	19.2V
	156	180	193	24V
4	153	173	183	30V
	175	222	245	19.2V
	165	198	215	24V
	160	187	200	30V

SAFETY

Location of fieldbus power supply carrier

Safe area

Location of field wiring

Zone 1, IIB hazardous area

Field wiring protection

Intrinsically safe

Safety description, each segment

14.8V, 359mA, 5.31W, 0.50µF*, 550µH*

* When used in accordance with IEC60079-27, there is no need to take into consideration Co and Lo.

Certification

See 'Approvals' table

Certification is compatible with

- Fieldbus FOUNDATION FF816-FISCO.
- IEC 60079-27 FISCO Standard
- EC Directive 94/9/EC

FIELDBUS TERMINATION

1 x fixed terminator and 1 x switchable terminator per host segment on module carrier
Fixed terminator per field segment inside each 9122-IS module

CONNECTIONS

Host fieldbus

2 x 3-way fixed rising cage-clamp screw terminals per segment
Conductor size: 0.14 to 2.5 mm²

Hazardous area fieldbus

3-way pluggable rising cage-clamp screw terminals per segment
Conductor size: 0.14 to 2.5 mm²

24V power

2-way pluggable rising cage-clamp screw terminal each for Power A and Power B
Conductor size: 0.14 to 2.5 mm²

Alarm

2-way fixed rising cage-clamp screw terminal
Conductor size: 0.14 to 2.5 mm²

ALARMS

Alarm contact rating

Max. 250V, 100mA (solid state)

Alarm contact status

Normally closed, open on failure of any FISCO power supply module or Supply Arbitration Module

MECHANICAL

Mounting

Surface mounting

Weight

6.5kg approx.

Dimensions (refer also to diagram)

255(w) x 354(h) x 154(d) mm

ENVIRONMENTAL

Ambient temperature

-20°C to +60°C (operating)
-40°C to +85°C (storage)

Ingress protection

IP20 to BS EN 60529 (Additional protection by means of enclosure)

LED INDICATORS

Carrier Power Inputs

	OFF	ON
Power (green)	Power fail	Power OK

Host PSU modules - 9126-PU

	OFF	ON
Seg1 - Seg4 (green)	Power fail	Power OK

FISCO Power Supply - 9122-IS-CM

	OFF	ON
Power (green)	Power fail or internal fault	Power OK
Fault (red)	Normal	Fault
Host Comm (yellow)	Comms failure	Comms OK
IS Comm (yellow)	Comms failure	Comms OK

Supply Arbitration Module (SAM) - 9129-IS

Active Mode	Active LED - ON	Standby LED - OFF
Standby Mode	Active LED - OFF	Standby LED - ON
Fault/Alarm Mode	Active LED or Standby LED - OFF or FLASHING*	

* Note: During startup, either of the LEDs may flash for up to 10 seconds - this is normal operation.

ORDERING INFORMATION

Description	Part Number
Redundant FISCO power supply system (4 segment, pluggable screw terminals, IIB Gas Group) Comprises: 8 x 9122-IS-CM, 8 x 9129-IS, 1 x 9109-CA-PS, 2 x 9126-PU	9109-22-PS
FISCO power supply (IIB Gas Group, pluggable carrier mount)	9122-IS-CM
Supply arbitration module	9129-IS
Host power supply module	9126-PU
Alarm blanking module (To defeat carrier alarm - if power supplies and supply arbitration modules are not fitted. Two required per segment)	9127-BLK
Module carrier (4 segment, pluggable screw terminals)	9109-CA-PS

REDUNDANCY BLOCK DIAGRAM (one segment shown)

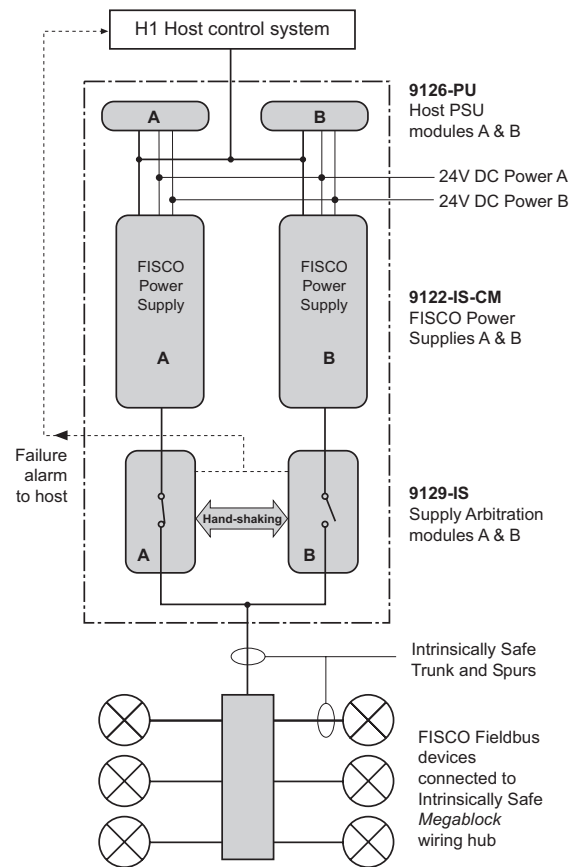

DIMENSIONS (mm)

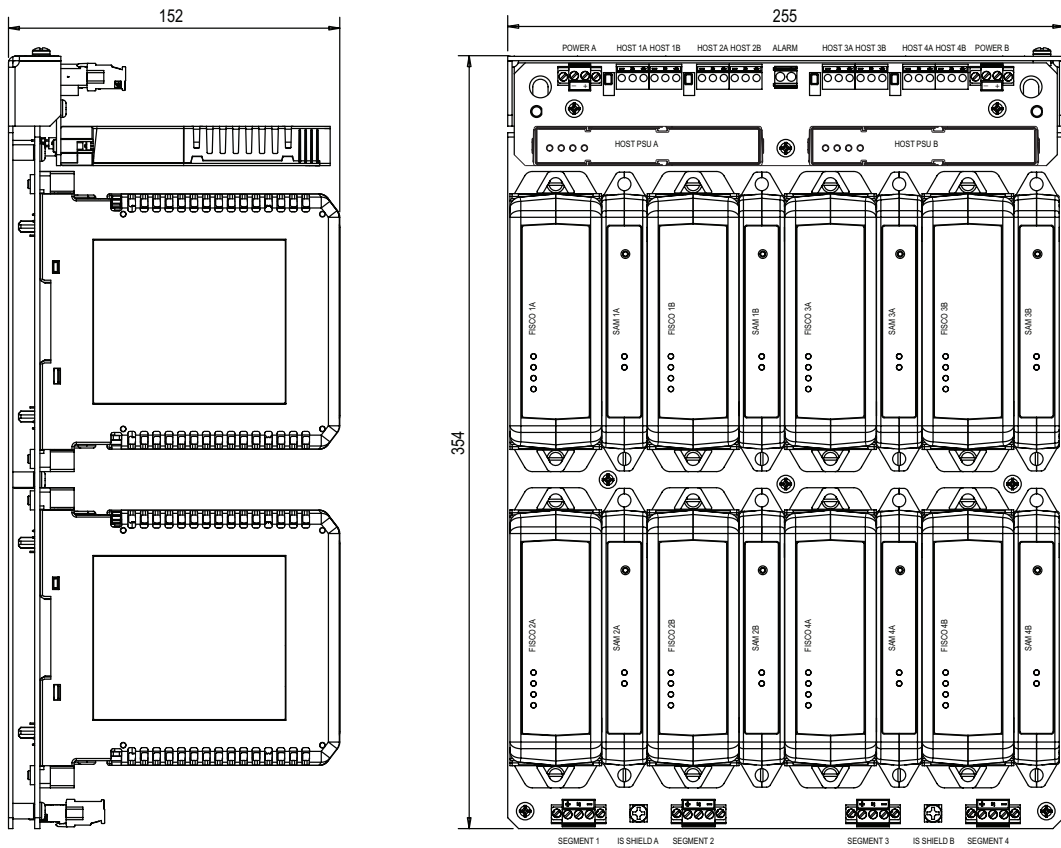

APPROVALS

Authority	ATEX	IECEX
Standards	EN 60079-0 EN 60079-11 EN 60079-27 EN 61241-11	IEC 60079-0 IEC 60079-11 IEC 60079-27 IEC 61241-11
Certification markings	E II (2) GD [Ex ib Gb] IIB (-20°C ≤ T _a ≤ 60°C) [Ex ib Db] IIIC (-20°C ≤ T _a ≤ 60°C)	[Ex ib Gb] IIB (-20°C ≤ T _a ≤ 60°C) [Ex ib Db] IIIC (-20°C ≤ T _a ≤ 60°C)
Certification number	Baseefa09ATEX0127	IECEXBAS 09.0055



Eaton Electric Limited,
Great Marlings, Butterfield, Luton
Beds, LU2 8DL, UK.
Tel: + 44 (0)1582 723633 Fax: + 44 (0)1582 422283
E-mail: mtlenquiry@eaton.com
www.mtl-inst.com

© 2017 Eaton
All Rights Reserved
Publication No. EPS 9109-22 Rev 3 010217
February 2017

EUROPE (EMEA):
+44 (0)1582 723633
mtlenquiry@eaton.com

THE AMERICAS:
+1 800 835 7075
mtl-us-info@eaton.com

ASIA-PACIFIC:
+65 6 645 9888
sales.mtl-sing@eaton.com

The given data is only intended as a product description and should not be regarded as a legal warranty of properties or guarantee. In the interest of further technical developments, we reserve the right to make design changes.

9121-IS

MTL FISCO Power supply IIC

- Intrinsically safe fieldbus trunk and spurs allows full live working in the hazardous area
- 120mA output current: supports 8 x 15mA IS fieldbus devices per power supply
- Fieldbus repeater
- Multidrop isolators on single fieldbus link
- 250V ac input/output/power supply isolation
- Switch selectable terminator on host side
- Fixed terminator on IS side
- Switch selectable power for host side
- Mountable in Zone 2



The MTL 9121-IS is a fieldbus repeater isolator which repeats the fieldbus signal from a safe area, Zone 2 fieldbus to an intrinsically safe fieldbus for connection to devices in Zone 1. The 9121-IS provides up to 120mA, typically powering up to 8 x 15mA field devices in Gas Group IIC.

The 9121-IS is certified to FISCO (Fieldbus Intrinsically Safe Concept) requirements in IEC60079-11: 2011 Equipment protection by intrinsic safety i and IEC 60079-25: 2010 Intrinsically Safe Electrical Systems. This allows the power supplied to the IS fieldbus to exceed the limit set in the original FF-816 IS physical layer profile. This increases the number of devices on an IS fieldbus from typically 4 x 20mA devices with maximum of 80m cable run, to up to 6 x 20mA devices with 400m cable run using the 9121-IS.

In addition, FISCO reduces the documentation required.

Intrinsically safe systems have been installed in accordance with IEC 60079-25: 2010 Intrinsically Safe Electrical Systems entity calculations or similar local code of practice. This requires:

- calculation of cable parameters
- comparison of safety descriptions
- creation of descriptive system document

The administrative work involved in carrying this out in accordance with the end users procedures is usually considerable. Simply adding a new field device to an IS segment will require all this documentation to be updated.

Fieldbus intrinsically safe systems can now also be installed in accordance with FISCO requirements in IEC 60079-25: 2010 Intrinsically Safe Electrical Systems.

This:

- eliminates need to calculate cable parameters
- reduces safety documentation to a list of devices
- allows addition of devices without a review of safety documentation
- as proven by test, allows longer cables with higher capacitance

To install a fieldbus system to the FISCO requirements in IEC 60079-25: 2010 Intrinsically Safe Electrical Systems the cable used in the system must comply with the following parameters:

Loop resistance Rc: 15 to 150 ohms/km
Loop inductance Lc: 0,4 to 1 mH/km
Capacitance Cc: 80 to 200 nF/km
Maximum length of each spur cable: 60 m in IIC and IIB
Maximum length of each trunk cable: 1 km in IIC 5 km in IIB

When cable which complies with this specification is used, no further consideration of cable parameters is necessary. Virtually any instrument cable suitable for a fieldbus signal will comply.

FOUNDATION™ fieldbus is a trademark of Fieldbus Foundation™, Austin, Texas.

MODULE SPECIFICATION

See also Common Specification

OUTPUT

Number of channels

One

Voltage

12.4V (min.) at 25°C (see note)

Design current

0 to 120mA

Current limit

>140mA

Output ripple

Complies with clause 22.6.2 of the fieldbus standard†

Minimum load

No load

Maximum cable length

Determined by IS load, see MTL Application Note AN9026 for details

Isolation

Input to output:	250V ac rms
Input and output to power supply:	250V ac rms
Power In	Um 40Vdc
Host Fieldbus	Um 253Vrms

INPUT

Input voltage

19.2 - 30V dc

Current consumption:

235mA (typical) 330mA (max.) at 20V
 190mA (typical) 265mA (max.) at 24V
 155mA (typical) 215mA (max.) at 30V

Power dissipation with 110mA load:

2.9W (typical) 4.3W (max.)

Input protection

Fuse + supply reversal diode

Note: Temperature coefficient 12mV/°C. If the power supply and fieldbus cable are operated at low temperatures, the reduced resistance of the cable more than compensates for the reduction in output voltage.

Fieldbus Foundation™ and FOUNDATION™ are trademarks of Fieldbus Foundation, Austin, Texas, USA.

† The applicable fieldbus specifications and standards are:

- FOUNDATION™ fieldbus 31.25 kb/s Physical Layer Profile Specification, document FF-816.
- IEC 61158-2:2014
- ISA-550.02-1992 for 31.25 kb/s fieldbus systems.

SAFETY

Location of module

Safe area, Zone 2, IIC T4 hazardous area.

Location of field wiring

Zone 1, IIC T4 hazardous area.

Field wiring protection

Intrinsically safe

Certification Code

ⓂII(2) GD [Ex ib Gb] IIC
 ⓂII 3 GD Ex nA IIC T4 Gc

Safety description

14V, 180mA, 2.52W, 0.20μF*, 300μH*

*When used in accordance with IEC/EN 60079-25:2010, there is no need to take into consideration Co and Lo.

Approvals

For the latest certificate information see www.mtl-inst.com/certificates

Certification is compatible with

Fieldbus FOUNDATION FF816-FISCO.
 FISCO requirements in IEC/EN60079-11 and IEC/EN 60079-25.
 ATEX Directive 2014/34/EU

MECHANICAL

Mounting

DIN rail/surface mounting

Module width

42mm

Weight

360g

LED INDICATORS

	OFF	ON
Power (green)	Power fail	Power OK
Fault (red)	Normal	Fault
Host Comm (yellow)	Comms failure	Comms OK
IS Comm (yellow)	Comms failure	Comms OK

COMMON SPECIFICATIONS

MECHANICAL

Mounting method

Flat panel or DIN - rail

DIN-rail types

'Top hat', 35 x 7.5mm to EN 50022 or 35 x 15mm to EN 50022

ENVIRONMENTAL

Ambient temp

Operating, optimum orientation

-40°C to +70°C

(except where stated in individual module specifications)

Operating, non-optimum orientation

-40°C to +50°C

(except where stated in individual module specifications)

Storage

-40°C to +85°C

Relative Humidity

5 to 95% RH (non-condensing)

Vibration - Operating, Storage & Transport

Sinusoidal Vibration EN 60068-2-6	10-500 Hz. 5 g for surface mounting, 1 g for DIN-rail mounting
Random Vibration BS2011:Part 2.1	20-500 Hz 5 g for surface mounting 1 g for DIN-rail mounting

Shock - Storage & Transport

EN 60068-2-32	1 m drop onto flat concrete
---------------	-----------------------------

Shock - Storage & Transport

EN 60068-2-27	30 g peak acceleration with 11 ms pulse width
---------------	--

Shock - Storage & Transport

EN 60068-2-27	30 g peak acceleration with 11 ms pulse width
---------------	--

Ingress Protection

IP20 to IEC/EN 60529

(Additional protection by means of enclosure).

Corrosive atmospheres:

Designed to meet ten year service in Class G3 corrosive environment, as defined by ISA Standard SP71.04

ELECTRICAL

EMC compliance

To EN 61326-1:2013 Electrical equipment for measurement, control and laboratory use - EMC requirements.

Class A equipment Table 2 - Industrial locations

Electrical safety

EN 61010-2-201

PHYSICAL NETWORK

IEC61158-2

FOUNDATION Fieldbus H1

Profibus PA

TERMINALS (PLUGGABLE)

Rising cage clamp screw terminals

Specify -PS

Conductor size: 0.14 to 2.5mm²

Spring clamp terminals

Specify - PC

Conductor size: 0.14 to 2.5mm²

FIELDBUS TERMINATOR

Host side

Selectable by switch on top of unit

IS side

Permanently connected terminator

HOST SIDE POWER (selectable by switch on top of unit)*

Voltage

14V minimum

Current

0 to 30mA

Output ripple

Complies with clause 22.6.2 of the fieldbus standard

Minimum load

No load

Maximum cable length

Determined by host side load

Terminal numbering

Host side		NI/IS connection	
1	Power Supply No 1 + ve	7	NI/IS fieldbus trunk +ve
2	Power Supply 0V	8	NI/IS fieldbus trunk shield
3	Power Supply No 2 +ve	9	NI/IS fieldbus trunk -ve
4	Fieldbus trunk -ve		
5	Fieldbus trunk shield		
6	Fieldbus trunk +ve		

* Note: When mounted in Zone 2, switches may only be operated if the equipment is de-energised or the area is known to be gas-free.

ORDERING INFORMATION

Host side	Host side
9121-IS-PC	FISCO power supply, IIC, with spring clamp terminals
9121-IS-PS	FISCO power supply, IIC, with screw terminals



Eaton Electric Limited,
Great Marlings, Butterfield, Luton
Beds, LU2 8DL, UK.
Tel: + 44 (0)1582 723633 Fax: + 44 (0)1582 422283
E-mail: mtlenquiry@eaton.com
www.eaton.com

© 2022 Eaton
All Rights Reserved
Publication No. EPS 9121-IS Rev H 011122
November 2022

EUROPE (EMEA):
+44 (0)1582 723633
mtlenquiry@eaton.com

THE AMERICAS:
+1 800 835 7075
mtl-us-info@eaton.com

ASIA-PACIFIC:
+65 6 645 9888
sales.mtlsing@eaton.com

The given data is only intended as a product description and should not be regarded as a legal warranty of properties or guarantee. In the interest of further technical developments, we reserve the right to make design changes.

9122-IS

MTL FISCO Power supply IIB

- Intrinsically safe fieldbus trunk and spurs allows full live working in the hazardous area
- 256mA output current: supports 16 x 15mA IS fieldbus devices per power supply
- Fieldbus repeater
- Multidrop isolators on single fieldbus link
- 250V ac input/output/power supply isolation
- Switch selectable terminator on host side
- Fixed terminator on IS side
- Switch selectable power for host side
- Mountable in Zone 2



The MTL 9122-IS is a fieldbus repeater isolator which repeats the fieldbus signal from a safe area, Zone 2 fieldbus to an intrinsically safe fieldbus for connection to devices in Zone 1. The 9122-IS provides up to 256mA, typically powering up to 16 x 15mA field devices in Gas Group IIB.

The 9122-IS is certified to FISCO (Fieldbus Intrinsically Safe Concept) requirements in IEC60079-11: 2011 Equipment protection by intrinsic safety i and IEC 60079-25: 2010 Intrinsically Safe Electrical Systems. This allows the power supplied to the IS fieldbus to exceed the limit set in the original FF-816 IS physical layer profile. This increases the number of devices on an IS fieldbus from typically 4 x 20mA devices with maximum of 80m cable run, to up to 12 x 20mA devices with 250m cable run using the 9122-IS.

In addition, FISCO reduces the documentation required.

Intrinsically safe systems have been installed in accordance with IEC 60079-25: 2010 Intrinsically Safe Electrical Systems entity calculations or similar local code of practice. This requires:

- calculation of cable parameters
- comparison of safety descriptions
- creation of descriptive system document

The administrative work involved in carrying this out in accordance with the end users procedures is usually considerable. Simply adding a new field device to an IS segment will require all this documentation to be updated.

Fieldbus intrinsically safe systems can now also be installed in accordance with FISCO requirements in IEC 60079-25: 2010 Intrinsically Safe Electrical Systems.

This:

- eliminates need to calculate cable parameters
- reduces safety documentation to a list of devices
- allows addition of devices without a review of safety documentation
- as proven by test, allows longer cables with higher capacitance

To install a fieldbus system to the FISCO requirements in IEC 60079-25: 2010 Intrinsically Safe Electrical Systems the cable used in the system must comply with the following parameters:

Loop resistance Rc: 15 to 150 ohms/km
Loop inductance Lc: 0,4 to 1 mH/km
Capacitance Cc: 80 to 200 nF/km
Maximum length of each spur cable: 60 m in IIC and IIB
Maximum length of each trunk cable: 1 km in IIC 5 km in IIB

When cable which complies with this specification is used, no further consideration of cable parameters is necessary. Virtually any instrument cable suitable for a fieldbus signal will comply.

FOUNDATION™ fieldbus is a trademark of Fieldbus Foundation™, Austin, Texas.

MODULE SPECIFICATION

See also Common Specification

OUTPUT

Number of channels

One

Voltage

13.1V (min.) at 25°C (see note)

Design current

0 to 256mA

Current limit

>280mA

Output ripple

Complies with clause 22.6.2 of the fieldbus standard†

Minimum load

No load

Maximum cable length

Determined by IS load, see MTL Application Note AN9026 for details

Isolation

Input to output:	250V ac rms
Input and output to power supply:	250V ac rms
Power In	Um 40Vdc
Host Fieldbus	Um 253Vrms

INPUT

Input voltage

19.2 - 30V dc

Current consumption:

380mA (typical) 495mA (max.) at 20V
 315mA (typical) 410mA (max.) at 24V
 255mA (typical) 330mA (max.) at 30V

Power dissipation with 240mA load:

4.1W (typical) 6W (max.)

Input protection

Fuse + supply reversal diode

Note: Temperature coefficient 12mV/°C. If the power supply and fieldbus cable are operated at low temperatures, the reduced resistance of the cable more than compensates for the reduction in output voltage.

Fieldbus Foundation™ and FOUNDATION™ are trademarks of Fieldbus Foundation, Austin, Texas, USA.

† The applicable fieldbus specifications and standards are:

- FOUNDATION™ fieldbus 31.25 kb/s Physical Layer Profile Specification, document FF-816.
- IEC 61158-2: 2014.
- ISA-550.02-1992 for 31.25 kb/s fieldbus systems.

SAFETY

Location of module

Safe area, Zone 2, IIC T4 hazardous area.

Location of field wiring

Zone 1, IIB T4 hazardous area.

Field wiring protection

Intrinsically safe

Certification Code

Ⓜ II(2) GD [Ex ib Gb] IIB
 Ⓜ II 3 GD Ex nA IIB T4 Gc

Safety description

14V, 180mA, 2.52W, 0.20µF*, 300µH*

*When used in accordance with IEC/EN 60079-25:2010, there is no need to take into consideration Co and Lo.

Approvals

For the latest certificate information see www.mtl-inst.com/certificates

Certification is compatible with

Fieldbus FOUNDATION FF816-FISCO.
 FISCO requirements in IEC/EN 60079-11 and IEC/EN 60079-25.
 ATEX Directive 2014/34/EU

MECHANICAL

Mounting

DIN rail/surface mounting

Module width

42mm

Weight

360g

LED INDICATORS

	OFF	ON
Power (green)	Power fail	Power OK
Fault (red)	Normal	Fault
Host Comm (yellow)	Comms failure	Comms OK
IS Comm (yellow)	Comms failure	Comms OK

* When used in accordance with IEC/TS 60079-27, there is no need to take into consideration Co and Lo.

COMMON SPECIFICATIONS

MECHANICAL

Mounting method

Flat panel or DIN-rail

DIN-rail types

'Top hat', 35 x 7.5mm to EN 50022 or 35 x 15mm to EN 50022

ENVIRONMENTAL

Ambient temp

Operating, optimum orientation

-40°C to +70°C
(except where stated in individual module specifications)

Operating, non-optimum orientation

-40°C to +50°C
(except where stated in individual module specifications)

Storage

-40°C to +85°C

Relative Humidity

5 to 95% RH (non-condensing)

Vibration - Operating, Storage & Transport

Sinusoidal Vibration EN 60068-2-6	10-500 Hz. 5 g for surface mounting, 1 g for DIN-rail mounting
Random Vibration BS2011:Part 2.1	20-500 Hz 5 g for surface mounting 1 g for DIN-rail mounting

Shock - Storage & Transport

EN 60068-2-32	1 m drop onto flat concrete
---------------	-----------------------------

Shock - Storage & Transport

EN 60068-2-27	30 g peak acceleration with 11 ms pulse width
---------------	--

Shock - Storage & Transport

EN 60068-2-27	30 g peak acceleration with 11 ms pulse width
---------------	--

Ingress Protection

IP20 to IEC/EN 60529
(Additional protection by means of enclosure).

Corrosive atmospheres:

Designed to meet ten year service in Class G3 corrosive environment, as defined by ISA Standard SP71.04

ELECTRICAL

EMC compliance

To EN 61326-1:2013 Electrical equipment for measurement, control and laboratory use- EMC requirements.
Class A equipment Table 2- Industrial locations.

Electrical safety

EN 61010-2-201

PHYSICAL NETWORK

IEC61158-2
FOUNDATION Fieldbus H1
Profibus PA

TERMINALS (PLUGGABLE)

Rising cage clamp screw terminals

Specify -PS
Conductor size: 0.14 to 2.5mm²

Spring clamp terminals

Specify -PC
Conductor size: 0.14 to 2.5mm²

FIELDBUS TERMINATOR

Host side

Selectable by switch on top of unit

IS side

Permanently connected terminator

HOST SIDE POWER (selectable by switch on top of unit)*

Voltage

14V minimum

Current

0 to 30mA

Output ripple

Complies with clause 22.6.2 of the fieldbus standard

Minimum load

No load

Maximum cable length

Determined by host side load

Terminal numbering

Host side		NI/IS connection	
1	Power Supply No 1 + ve	7	NI/IS fieldbus trunk +ve
2	Power Supply 0V	8	NI/IS fieldbus trunk shield
3	Power Supply No 2 +ve	9	NI/IS fieldbus trunk -ve
4	Fieldbus trunk -ve		
5	Fieldbus trunk shield		
6	Fieldbus trunk +ve		

* Note: When mounted in Zone 2, switches may only be operated if the equipment is de-energised or the area is known to be gas-free.

ORDERING INFORMATION

Host side	Host side
9122-IS-PC	FISCO power supply, IIB, with spring clamp terminals
9122-IS-PS	FISCO power supply, IIB, with screw terminals



Eaton Electric Limited,
Great Marlings, Butterfield, Luton
Beds, LU2 8DL, UK.
Tel: + 44 (0)1582 723633 Fax: + 44 (0)1582 422283
E-mail: mtlenquiry@eaton.com
www.eaton.com

© 2022 Eaton
All Rights Reserved
Publication No. EPS 9122-IS Rev I 011122
November 2022

EUROPE (EMEA):
+44 (0)1582 723633
mtlenquiry@eaton.com

THE AMERICAS:
+1 800 835 7075
mtl-us-info@eaton.com

ASIA-PACIFIC:
+65 6 645 9888
sales.mtlsing@eaton.com

The given data is only intended as a product description and should not be regarded as a legal warranty of properties or guarantee. In the interest of further technical developments, we reserve the right to make design changes.



F606

termination board for Yokogawa ALF111 Fieldbus Communication Module

- Integrated connection to ALF111 Foundation fieldbus™ communication module
- Compact, DIN-rail mountable
- Supports single or redundant ALF111 cards
- Redundant 24V dc power connections
- Built-in terminators
- Supports four fieldbus segments
- Cable assembly to NET9000 FISCO/FNICO power supplies available

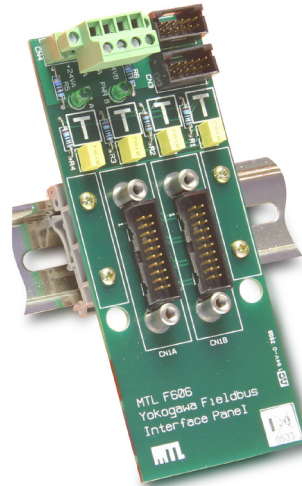

The **F606 Termination Board** provides a compact, low-cost interface between a Yokogawa ALF111 fieldbus communication module and MTL's NET9000 FISCO/FNICO power supplies. Connection to the F606 termination board is simple using the ALF111 with the connectors option and the Yokogawa AKB336 cable.

A **ready-made cable assembly** (FCAB-02) eliminates the need for additional wiring between the F606 termination panel and the host side of the NET9000 supplies.

Redundant 24V dc input connections, each with an LED indicator, provide power to the FISCO/FNICO power supplies. Mounting clips are ready fitted for easy DIN-rail mounting and each fieldbus segment has its own built-in terminator.

SPECIFICATION

Location of equipment
Safe area

OUTPUTS

Number of channels
Four

MECHANICAL

Mounting method
DIN-rail mounting kit

DIN-rail types

'Top hat', 35mm x 7.5mm or 35mm x 15mm to EN 50022

24V DC input terminals

Two-part, pluggable connector with rising-cage-clamp screw terminals

Conductor size: 0.14 to 2.5mm²

System connections

Redundant connectors CN1A and CN1B via AKB336 cables to ALF111 cards.

Terminators

Fixed terminator for each fieldbus segment

ENVIRONMENTAL

Ambient temp

-40°C to +70°C

Storage

-40°C to +85°C

Ingress protection

IP20 to BS EN 60529 (Additional protection by means of enclosure)

PHYSICAL NETWORKS

IEC 61158-2
FOUNDATION™ fieldbus H1

ORDERING INFORMATION

PART No	DESCRIPTION
F606	Fieldbus Termination Board
FCAB-02	Cable Assembly, NET9000

The given data is only intended as a product description and should not be regarded as a legal warranty of properties or guarantee. In the interest of further technical developments, we reserve the right to make design changes.



EUROPE (EMEA): +44 (0)1582 723633
enquiry@mtl-inst.com

THE AMERICAS: +1 800 835 7075
csinfo@mtl-inst.com

ASIA-PACIFIC: +65 6 487 7887
sales@mtlsing.com.sg

EPS-F606 Rev1 090410

F606 FIELDBUS TERMINATION BOARD

F606 DIMENSIONS

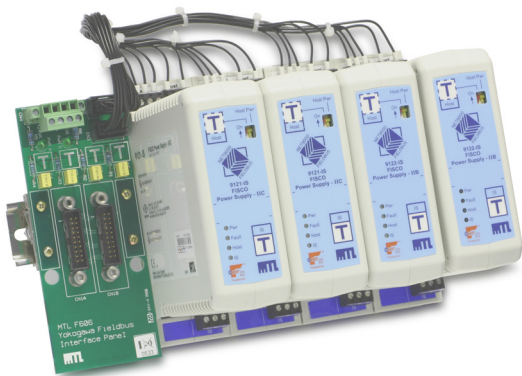
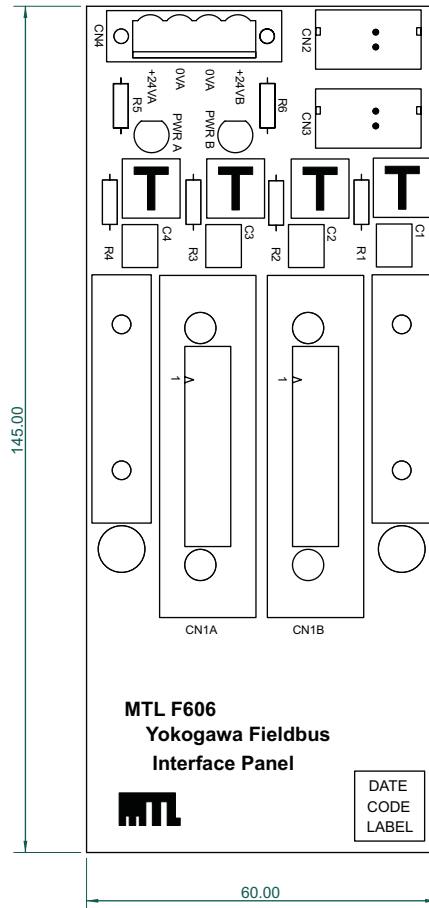

F606 used with NET9000 FISCO power supplies and FCAB-02 cable assembly



Cable assembly type FCAB-02

The given data is only intended as a product description and should not be regarded as a legal warranty of properties or guarantee. In the interest of further technical developments, we reserve the right to make design changes.



EUROPE (EMEA): +44 (0)1582 723633
enquiry@mtl-inst.com

THE AMERICAS: +1 800 835 7075
csinfo@mtl-inst.com

ASIA-PACIFIC: +65 6 487 7887
sales@mtlsing.com.sg

EPS-F606 Rev1 090410



F656A

remote termination panel for use with Honeywell Experion PKS FIM

- Unpowered, non-redundant
- format
- Compact, DIN-rail mountable
- Integrated connection to a single Honeywell Experion PKS Fieldbus Interface Module
- Redundant 24V dc power connections
- Alarm contact on 24V dc power failure
- Switchable terminators
- Supports two fieldbus segments
- Built-in cable connection to NET9000 FISCO/FNICO power supplies

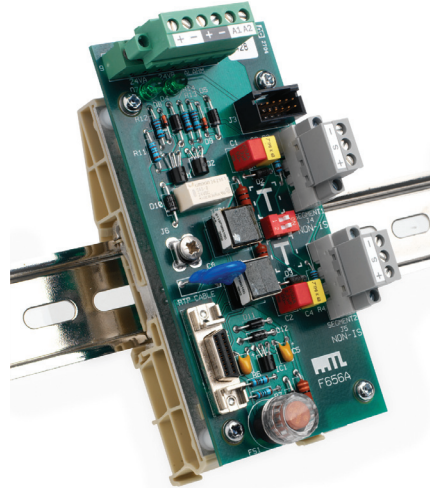

The **F656A Remote Termination Panel** provides a compact, low-cost interface between Honeywell's Experion PKS Fieldbus Interface Module (FIM) and external fieldbus power supplies. It provides a single FIM connection using a standard Honeywell RTP cable. The unit accommodates the fieldbus conditioning components required to support two FOUNDATION™ Fieldbus H1 segments.

The RTP does not power the fieldbus segments, but is intended to be used with external fieldbus supplies such as the MTL5995 or MTL-Relcom FPS Series. For non-redundant power, select the FPS-D/-DT dual power supply.

Applications requiring redundant power may be satisfied using the F656A with two FPS-I supplies, but the F650A redundant power system is recommended where redundancy of power and host communications are required.

To minimise wiring effort in FISCO and FNICO applications, a cable assembly is available for easy connection to MTL's NET9000 power supplies. The cable eliminates the need for additional wiring between the termination panel and the host side of the NET9000 supplies. When used with other external fieldbus conditioners, such as the MTL-Relcom FPS Series, the field wiring to each segment is connected by means of a two-part pluggable connector.

Optionally redundant 24V dc connections provide power to the termination panel and, where appropriate, to the FISCO/FNICO power supplies. Failure of either 24V dc supply is signalled by means of a volt-free relay contact. An LED indicator is provided on each 24V dc input. Easy DIN-rail mounting is achieved by means of built-in mounting clips. Each segment has a switchable fieldbus terminator.

SPECIFICATION

Location of equipment
Safe area

OUTPUT

Number of channels
Two

DC INPUT

Input voltage
19.2 - 30V DC

Current consumption
(stand-alone, without NET9000 power supplies)
1mA (typical) at 18V
10mA (typical) at 19V
10mA (typical) at 19.2V
20mA (typical) at 24V
25mA (typical) at 25V

Isolation

Fieldbus to power supply: 250V AC rms withstand

ALARMS

Alarm contact rating
1A max @ 30V DC max

Alarm contact status
Normally closed; open on alarm

Alarm threshold
Input <18V DC; no overvoltage protection

MECHANICAL

Mounting method
DIN-rail mounting kit

DIN-rail types
'Top hat', 35mm x 7.5mm or 35mm x 15mm to EN 50022

24V DC Input and Alarm Contact Terminals
Two part pluggable connector with fixed rising cage clamp screw terminals
Conductor size: 0.14 to 2.5mm²

Fieldbus Terminals
Two-part pluggable connector with fixed rising cage clamp screw terminals
Conductor size: 0.14 to 2.5mm²

System Connections

System Connections: standard RTP cables to Experion - PKS Fieldbus Interface Module.
Screen Ground: to connect all fieldbus cable screens to a common point (cabinet earth).

ENVIRONMENTAL

Ambient temp
-40°C to +65°C

Storage
-40°C to +85°C

Ingress Protection
IP20 to BS EN 60529 (Additional protection by means of enclosure)

PHYSICAL NETWORKS

IEC 61158-2
Foundation Fieldbus H1

ORDERING INFORMATION

The cable assembly FCAB-01 should be ordered separately if the F656A is to be used with NET9000 FISCO or FNICO power supplies.

PART No	DESCRIPTION
F656A	Fieldbus Remote Termination Panel
FCAB-01	Cable Assembly, NET9000

The given data is only intended as a product description and should not be regarded as a legal warranty of properties or guarantee. In the interest of further technical developments, we reserve the right to make design changes.



EUROPE (EMEA): +44 (0)1582 723633
enquiry@mtl-inst.com

THE AMERICAS: +1 800 835 7075
csinfo@mtl-inst.com

ASIA-PACIFIC: +65 6 487 7887
sales@mtlsing.com.sg

EPS-F656A Rev1 090410

F656A FIELDBUS REMOTE TERMINATION PANEL

F656A DIMENSIONS

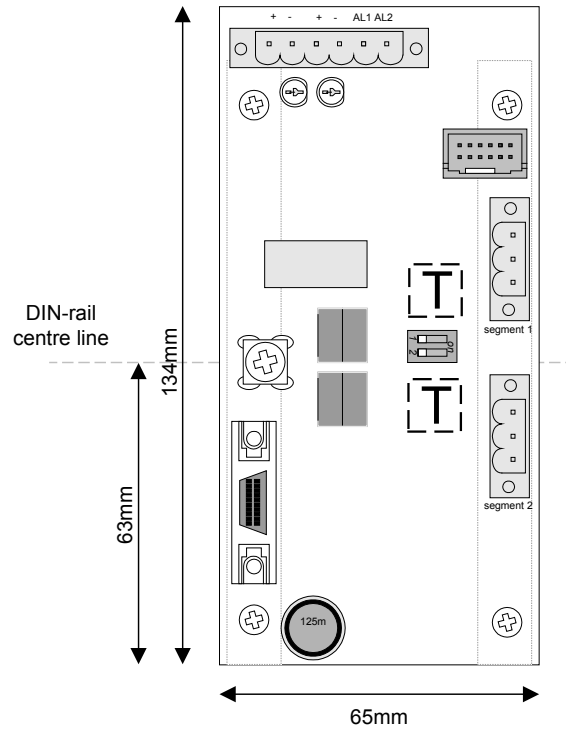

F656A used with NET9000 FISCO power supplies and FCAB-01 cable assembly



Cable assembly type FCAB-01

The given data is only intended as a product description and should not be regarded as a legal warranty of properties or guarantee. In the interest of further technical developments, we reserve the right to make design changes.



EUROPE (EMEA): +44 (0)1582 723633
enquiry@mtl-inst.com

THE AMERICAS: +1 800 835 7075
csinfo@mtl-inst.com

ASIA-PACIFIC: +65 6 487 7887
sales@mtlsing.com.sg

EPS-F656A Rev1 090410

COMMON SPECIFICATIONS NET9000 POWER SUPPLIES

SYSTEM SPECIFICATION

MECHANICAL

Mounting method

Flat panel or DIN-rail

DIN-rail types

'Top hat', 35 x 7.5mm to EN 50022 or 35 x 15mm to EN 50022

ENVIRONMENTAL

Ambient temp

Operating, optimum orientation *

-40°C to +70°C

(except where stated in individual module specifications)

Operating, non-optimum orientation *

-40°C to +50°C

(except where stated in individual module specifications)

Storage

-40°C to +85°C

Relative Humidity

5 to 95% RH (non-condensing)

Vibration - Operating, Storage & Transport

Sinusoidal Vibration EN 60068-2-6	10-500 Hz. 5 g for surface mounting, 1 g for DIN-rail mounting
Random Vibration BS2011:Part 2.1	20-500 Hz 5 g for surface mounting 1 g for DIN-rail mounting

Shock - Storage & Transport

EN 60068-2-32	1 m drop onto flat concrete
---------------	-----------------------------

Shock - Operating

EN 60068-2-27	30 g peak acceleration with 11 ms pulse width
---------------	--

Ingress Protection

IP20 to BS EN 60529

(Additional protection by means of enclosure).

Corrosive atmospheres:

Designed to meet ten year service in Class G3 corrosive environment, as defined by ISA Standard SP71.04.

ELECTRICAL

EMC compliance

To EN61326:1998 Electrical equipment for measurement, control and laboratory use - EMC requirements.

Electrical safety

EN 61010-1

HAZARDOUS AREA APPROVALS

Location of equipment

Safe area or Class 1, Div 2, Groups A-D, T4 hazardous location or Zone 2, IIC T4 hazardous area.

Location of field wiring

See individual data sheets.

PHYSICAL NETWORK

IEC61158-2

FOUNDATION Fieldbus H1

Profibus PA (9121-IS and 9122-IS only)

TERMINALS (PLUGGABLE)

Rising cage clamp screw terminals

Specify -PS

Conductor size: 0.14 to 2.5mm²

Spring clamp terminals

Specify -PC

Conductor size: 0.14 to 2.5mm²

FIELDBUS TERMINATOR

Host side

Selectable by switch on top of unit

NI/IS side

Permanently connected terminator

HOST SIDE POWER (selectable by switch on top of unit)

Voltage

14V

Current

0 to 30mA

Output ripple

Complies with clause 22.6.2 of the fieldbus standard

Minimum load

No load

Maximum cable length

Determined by host side load

Terminal numbering

Host side		NI/IS connection	
1	Power Supply No 1 + ve	7	NI/IS fieldbus trunk +ve
2	Power Supply 0V	8	NI/IS fieldbus trunk shield
3	Power Supply No 2 +ve	9	NI/IS fieldbus trunk -ve
4	Fieldbus trunk -ve		
5	Fieldbus trunk shield		
6	Fieldbus trunk +ve		

ORDERING INFORMATION

Model No.	Description
9111-NI-PC	FNICO power supply, IIC, with spring clamp terminals
9111-NI-PS	FNICO power supply, IIC, with screw terminals
9112-NI-PC	FNICO power supply, IIB, with spring clamp terminals
9112-NI-PS	FNICO power supply, IIB, with screw terminals
9121-IS-PC	FISCO power supply, IIC, with spring clamp terminals
9121-IS-PS	FISCO power supply, IIC, with screw terminals
9122-IS-PC	FISCO power supply, IIB, with spring clamp terminals
9122-IS-PS	FISCO power supply, IIB, with screw terminals
9321-SC	Spur Connector - Entity (for use with 9121-IS)
9322-SC	Spur Connector - Ex ia
9323-SC	Spur Connector - Entity (for use with 9122-IS or 9121-IS)

The given data is only intended as a product description and should not be regarded as a legal warranty of properties or guarantee. In the interest of further technical developments, we reserve the right to make design changes.



EUROPE (EMEA): +44 (0)1582 723633
enquiry@mtl-inst.com

THE AMERICAS: +1 800 835 7075
csinfo@mtl-inst.com

ASIA-PACIFIC: +65 6 487 7887
sales@mtlsing.com.sg

EPS9000 RevD 010410